

<b>Test Code Sheet Number</b>	<b>2</b>	<b>2</b>	<b>1</b>	<b>3</b>	<b>1</b>
-------------------------------	----------	----------	----------	----------	----------

TEST CODE SHEET

---

**1. TYPE OF TEST(S)**

Dimensional

**2. WATER REGULATIONS REQUIREMENTS FOR FITTINGS**

Schedule 2

15-(1) .... every water system shall contain an adequate device or devices for preventing backflow of fluid from any appliance, fitting or process from occurring.

**3. BRITISH STANDARDS OR WATER SPECIFICATION, DEEMED TO SATISFY WATER REGULATIONS REQUIREMENTS**

3.1 Fittings with 'kitemarks' which are deemed to satisfy the requirements of regulations are listed in the directory.

**4. TEST PROCEDURE**

4.1 Tests applicable to the following:-

**TYPE AA AIR GAPS**

Devices for the prevention of contamination by backflow.

---

**(A) TYPE AA AIR GAPS (Derived from PrEN 13076)**

TEST METHOD

**i. SCOPE**

This procedure specifies the characteristics of type AA air gaps. Air gaps that comply with the requirements of this procedure are devices for protection of potable water installations from pollution.

In addition to factory assembled products this procedure includes requirements for site constructed air gaps.

This is a performance criteria for type AA air gaps. Materials of construction must be fit for the purpose and application to ensure compliance with this procedure during normal working use.

**ii. DEFINITIONS**

**ii.i Air gap family 'A' Type AA.**

An 'AA' air gap is a visible, unobstructed and complete air gap, placed permanently and vertically between the lowest point of the inlet feed orifice and the highest physical point around the rim of the receiving vessel.

**ii.ii Spill-over Level**

The level at which water in an appliance or cistern will spill-over the top edge of the receiving vessel if the inflow exceeds the outflow through the outlet and any overflow with all outlets blocked.

**ii.iii Diameter 'D' Bore**

Diameter 'D' is the maximum internal diameter found within the last metre of the supply pipe or the DN of the inlet connection.

<b>Test Code</b>					
<b>Sheet</b>	2	2	1	3	1
<b>Number</b>					

Issue No: 4  
Date of issue: July 2000

Sheet 2 of 5

**ii.iv Maximum level**

The highest water level (G) reached above the spillover level under positive pressure fault condition with all outlets closed.

**ii.v Splash**

When contamination from, micro biological or viral elements is likely to occur and when maintaining the maximum flow rate at the normal operational water level, should contact be observed between the upstream components and the liquid in the receiving vessel due to the splashing, foaming or turbulence, the air gap should be increased to a point where no contact is observed.

**ii.vi Graphic symbol**

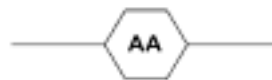

**FIG 1**

**iii. DESIGNATION**

The air gap is designated by the following:

- the reference to this standard.
- its Family, its Type.
- the DN of the feed pipe.

**iv. MATERIALS**

**iv.i Materials choice**

The manufacturer shall state the type of materials chosen in his technical and commercial documents.

The surface condition of materials in contact with water shall be chosen to be the least inclined to scale.

The materials used upstream and including the atmospheric outlet opening must comply with the relevant Standards, quality requirements and criteria for drinking water installations BS6920 (i.e. may not release substances in concentrations which can be harmful to the users of the drinking water installation).

The choice of other material is discretionary but shall be suitable for the intended use of the appliance (temperature, corrosion, scale, etc).

There are no special requirements concerning the materials downstream of the atmospheric outlet opening, provided they do not have any harmful effect on the upstream part.

<b>Test Code</b>					
<b>Sheet</b>	2	2	1	3	1
<b>Number</b>					

Issue No: 4  
Date of issue: July 2000

Sheet 3 of 5

**v. DESIGN**

**v.i General**

The protection assembly comprises two parts:

- a water inlet device.
- a receiving vessel (container).

The feed pipe and any flow control device shall be fixed external to any of the receiving vessel walls. The assembly must be so fixed that the air gap is permanently maintained and unrestricted.

**v.ii Water Inlet Device**

- v.ii.i Every float-operated valve or other device which controls the inflow of water to a receiving vessel shall be securely and rigidly fixed.
- v.ii.ii Every feed pipe supplying water to such a valve or other device shall be fixed in its position to prevent it from moving or buckling.
- v.ii.iii The direction of flow from a feed pipe into the receiving vessel shall be into air at atmospheric pressure, downwards and not more than 15° from the vertical.
- v.ii.iv The discharge from the feed pipe shall not be compromised by any object within 2D, measured horizontally and vertically downward (see Figure 3).
- v.ii.v Where non-circular pipes are used, the bore shall be taken as the internal diameter of a circular pipe having the same cross-sectional areas as the non-circular pipe.

**5. ACCEPTANCE CRITERIA**

**5.1 Air Gap Distance (see Figures 2 and 3)**

**5.1.1 Single inlets**

In the case of a single feed pipe to a single vessel having a continuous, unobstructed overflow around the top, the distance, 'A', shall not be less than the value:

$$A \geq 2 D \text{ but not less than } 20 \text{ mm (see Figure 2).}$$

Where the spillover rim is not horizontal the smallest vertical distance between the receiving vessel and the feed pipe orifice will be used.

Alternatively, by test;

Vessels having a variable height rim can be assessed only if:

- (a) they can be tested in a maximum positive fault condition, and
- (b) the air gap between the maximum fault level and the inlet device outlet can be maintained.

The maximum level is determined by measurement of the depth of water above the spill over level, with the inflow equal to  $Q = 0.14D^2$  in litres/min, or a dynamic pressure of 10 bar if the flow rate Q cannot be achieved, where D is the bore of supply pipe, and with all outlets including optional warning pipes closed, based on a velocity of 3 metres/sec or the maximum recommended flow rate for manufactured appliances when the flow rate is > than Q.

It is assumed that when the water supply to the receiving vessel is under critical vacuum conditions, the water level is the spill over level, not the maximum water level.

<b>Test Code</b>					
<b>Sheet</b>	<b>2</b>	<b>2</b>	<b>1</b>	<b>3</b>	<b>1</b>
<b>Number</b>					

Issue No: 4  
Date of issue: July 2000

Sheet 4 of 5

### 5.1.2 Multiple inlets

In the case of multiple feed pipes to a single vessel having a continuous unobstructed overflow around the spill over, the distance, 'A' shall not be less than the value:

$A \geq 2 \times$  the total sum of all inlet bore diameters (D), but not less than 20mm.

### 5.1.3 Backflow / Back Pressure

If the receiving vessel can be subject to positive pressure backflow it is important that the inlet orifice is positioned so that it cannot be contaminated by the ascending / returning backflow fluid

### Unrestricted air gap

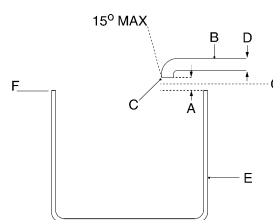

FIG 2

A = AIR GAP  
 B = FEED PIPE  
 C = POINT OF FEED ORIFICE  
 D = INTERNAL DIAMETER OF FEED PIPE (BORE)  
 E = RECEIVING VESSEL  
 F = SPILL-OVER  
 G = MAXIMUM LEVEL

Test Code					
Sheet	2	2	1	3	1
Number					

Issue No: 4  
Date of issue: July 2000

Sheet 5 of 5

Options for feed pipes

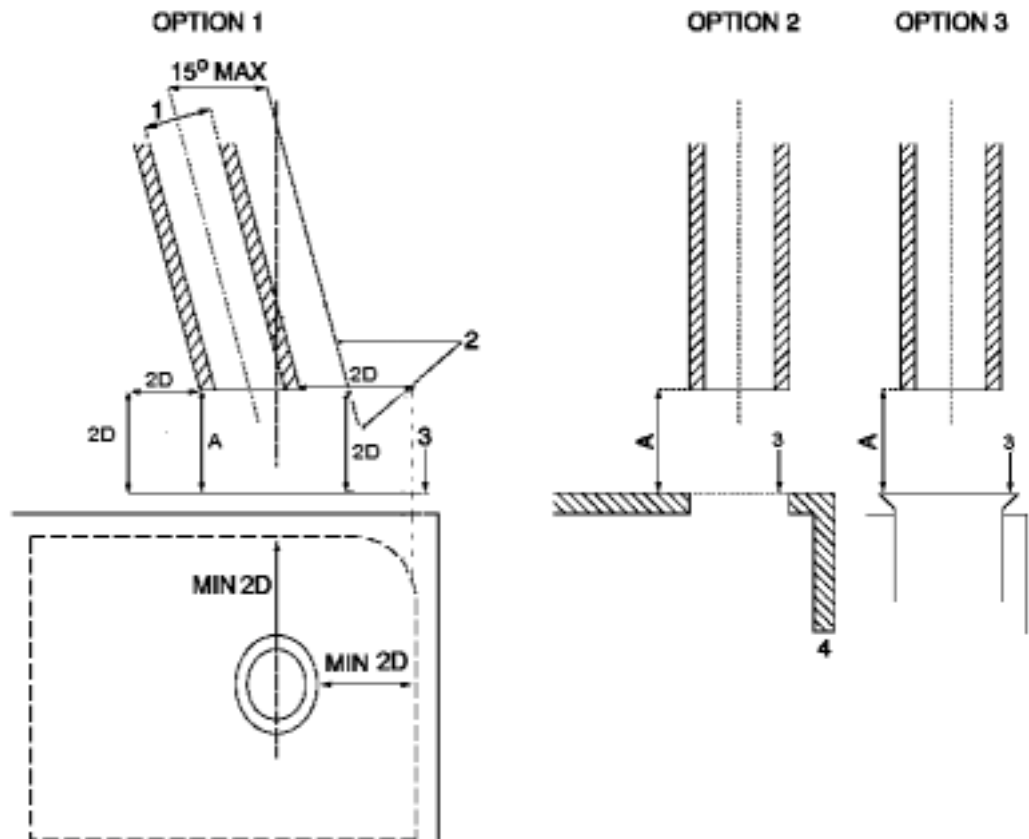

FIG 3

- 2 = LIMIT OF OBSTRUCTION
- 3 = SPILL-OVER LEVEL
- 4 = INSULATION
- A = AIR GAP
- D = DIAMETER BORE